

SPECIFICATION

1. PHYSICAL DIMENSION(UNIT: m/m):

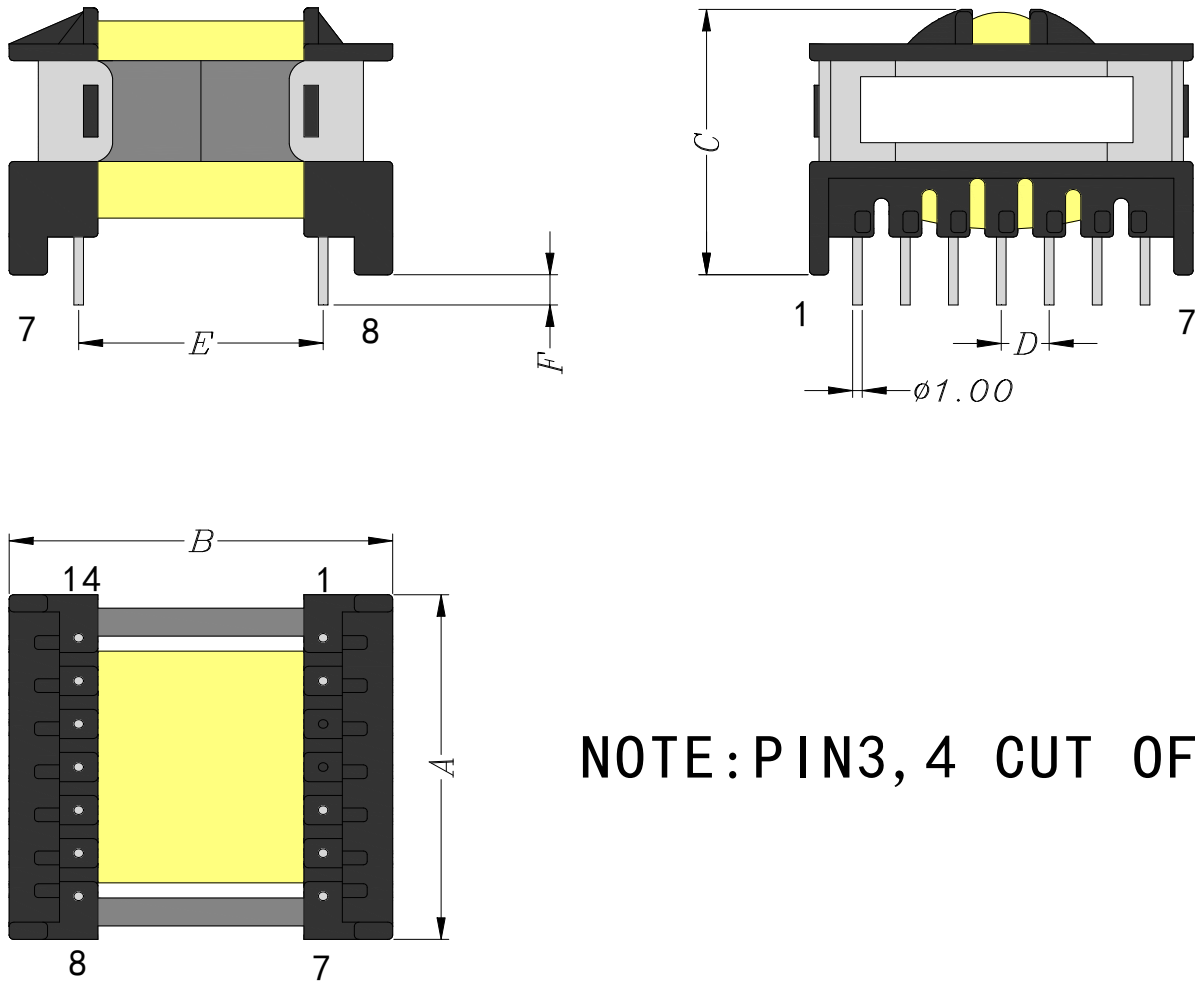

NOTE: PIN 3, 4 CUT OFF

- ※DIMENSIONS WITHOUT TOLERANCE ARE APPROX
- ※DIMENSION DOES NOT INCLUDE SOLDER USED ON COILS

LEAD FREE

DIM	A	B	C	D	E	F							
	MAX	MAX	MAX	+/-0.1	+/-0.1	+/-0.5							
SPEC	40.5	42.0	34.0	5.0	25.5	4.5							
							DESCRIPTION		TRANSFORMER				
							Customer P/N						
							FERRIWO P/N		FWPT-ETD34H-112K				
SPEC. NO.	PS-1001-009				PREPARED		APPROVED						

SPECIFICATION

2.WINDING TABLE:

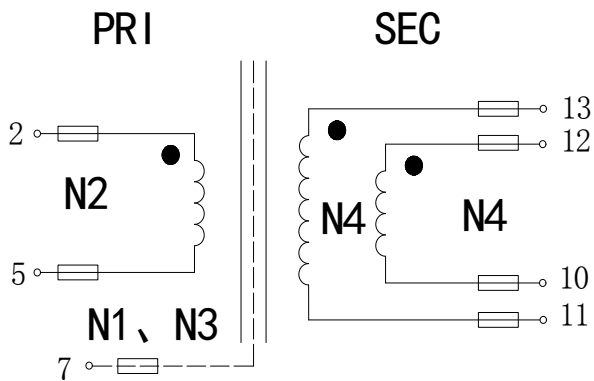

3.WINDING:

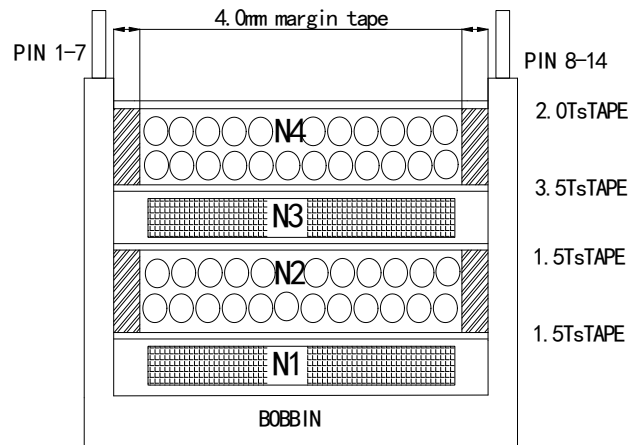

4.WINDING TABLE:

Winding NO.	Margin Tape	PIN	Wire & Wire Copper	Turns	Winding Type	Tape Layer	Tube
N1	0	7~			Centre	1.5	F≈10.0mm
N2	4.0mm	2~5			Compact	1.5	F=S≈10.0mm
N3	0	7~			Centre	3.5	F≈10.0mm
N4	4.0mm	12~10 13~11			Compact	2.0	F=S≈10.0mm F=S≈10.0mm

NOTE:

1. Products should be vacuum impregnation

*VARNISH RATIO: 1:1

*VACUUM TIME: 15~20minutes

*BAKED TEMPERATURE : 120°C±10°C, 1~1.5hours

2.The copper foil should be connected pin7 with 2UEW φ 0.35mm

LEAD FREE

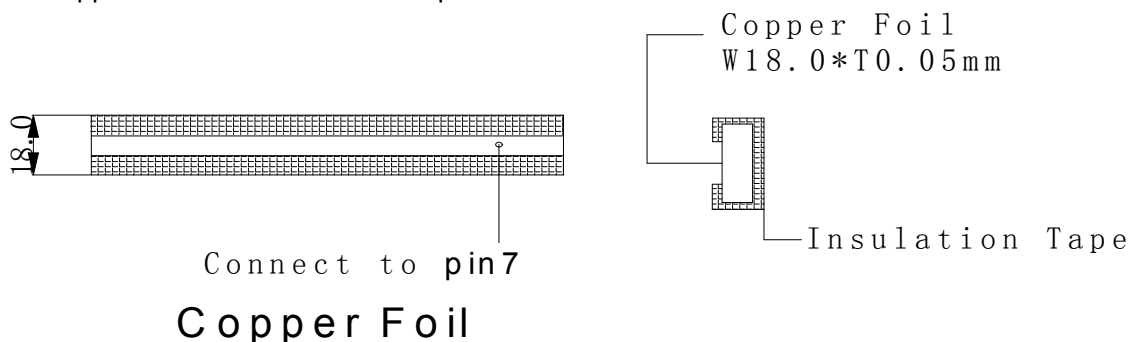

DESCRIPTION

TRANSFORMER

Customer P/N

FERRIWO P/N

FWPT-ETD34H-112K

SPEC. NO.

PS-1001-009

PREPARED

APPROVED

SPECIFICATION

5. ELECTRONICAL CHARACTERISTIC:

TEST CONDITION : TEMPERATURE AT 25°C
HUMIDITY AT 65 ±5% RH

TEST ITEM	TEST CONDITION	RESULT
INDUCTANCE CH-3250	@100.0KHz,0.25V (2~5) (12~10) (13~11)	1.15mH±10% 45.0uH±10% 45.0uH±10%
LEAKAGE INDUCTANCE CH-3250	@100KHz,0.25V (2~5)	45.0μH MAX SHORT PIN 10,11,12,13
D.C.R CH-502	(2~5) (12~10) (13~11)	475mΩ±15% 26mΩ±15% 26mΩ±15%
HI-POT TEST CH-9052	@ 2mA 3SEC (AC)	P<->S 4.0 KV; P、S<-> CORE 0.5KV;

LEAD FREE



DESCRIPTION

TRANSFORMER

Customer P/N

FERRIWO P/N

FWPT-ETD34H-112K

SPEC. NO.

PS-1001-009

PREPARED

APPROVED

SPECIFICATION

6. MATERIAL LIST :

ITEM		MATERIAL	SUPPLIER OR MANUFACTURER	TEMPRATING
1	CORE	FW40 OR EQUIVALENT	HAINING FERRIWO ELECTRONICS CO., LTD.	
2	BOBBIN	PHENOLIC OR EQUIVALENT	SUMITOMO BAKELITE CO., LTD. UL NO E41429	150°C
3	WIRE	2UEW	PACIFIC ELECTRIC WIRE&CABLE(SHENZHEN) CO. LTD UL NO E84081	155°C
4	COPPER FOIL	0.05*18.0mm/22.0mm	YAHUA STICKING TAPE CO.,LTD	
5	MARGIN TAPE	WF-2902	YAHUA STICKING TAPE CO.,LTD UL NO E324093	130°C
6	TAPE	CT280	YAHUA STICKING TAPE CO.,LTD UL NO E165111	130°C
7	VARNISH	R-1038	JOHN C DOLPH CO BC-346A UL NO E317427	130°C
8	FLUX	TF9100	LINAN GUITONG CHEMICAL TECHNICAL CO.,LTD	
9	TIN	Sn99.3Cu0.7	HAINING ZHUCHANG METAL FOIL CO;LTD	
10	TUBE	TEFLON TUBE	GREAT HOLDING INDUSTRIAL CO.,LTD UL NO E156256	200°C

LEAD FREE



DESCRIPTION

TRANSFORMER

Customer P/N

FERRIWO P/N

FWPT-ETD34H-112K

SPEC. NO.

PS-1001-009

PREPARED

APPROVED